



Perioperative myocardial ischemia reperfusion injury

Stanton K. Sherman, MD^{a,b,*}

^a*Department of Anesthesiology, Perioperative and Pain Medicine, Brigham and Women's Hospital,
75 Francis Street Boston, MA 02115, USA*

^b*Harvard Medical School, Boston, MA, USA*

Although advances in anesthetic and surgical techniques currently allow most patients to undergo coronary artery bypass grafting (CABG) procedures without significant mortality, more than 25% of this surgical population may still experience substantial morbidity related to adverse perioperative cardiovascular outcomes [1–4]. Stroke, myocardial infarction (MI), ventricular failure, and perioperative dysrhythmias can directly affect the length of hospital stay, the cost of hospitalization, and the functional capacity of the patients at discharge, and can ultimately contribute to mortality [4].

The etiology of myocardial dysfunction after CABG is often multifactorial, yet frequently involves perioperative myocardial ischemia. The myocardium may be particularly susceptible to ischemia during CABG surgery because of underlying coronary artery disease (CAD), perioperative hemodynamic instability, inadequate protection during cardiopulmonary bypass (CPB), coronary artery embolization, or technical complications (ie, incomplete revascularization and graft spasm or kinking). Although prolonged myocardial ischemia alone can jeopardize the structural and biochemical integrity of the cells, limited oxygen deprivation (<20 minutes) is usually associated with only transiently depressed myocardial contractility [5]. Paradoxically, the restoration of blood flow after sustained myocardial ischemia (>45 minutes) results in a phenomenon known as myocardial ischemia reperfusion (I–R) injury, wherein the tissue injury after reperfusion is greater than that produced by ischemia alone.

Perioperative myocardial I–R injury involves the generation of reactive oxygen species (ROS) on the restoration of oxygen (O₂) delivery and alterations

Dr. Sherman has received financial support for research sponsored by Procter and Gamble Pharmaceuticals, Mason, OH, and Alexion Pharmaceuticals Inc., Cheshire, CT.

* Department of Anesthesiology, Perioperative and Pain Medicine, Brigham and Women's Hospital, 75 Francis Street Boston, MA 02115.

E-mail address: sherman@zeus.bwh.harvard.edu

in intracellular calcium (Ca^{2+}) homeostasis. In addition, the activation of several proinflammatory pathways, including the complement, coagulation, and cytokine cascades, can exacerbate tissue injury and the functional impairment initiated by the original ischemic insult [6]. Thus, myocardial I–R injury involves a complex pathophysiologic process that contributes significantly to perioperative cardiac dysfunction and associated morbidity. Therefore, a significant effort has been made to develop novel surgical techniques and pharmacologic agents that may reduce the generation and subsequent pathophysiologic consequences of proinflammatory mediators. In this article, the pathophysiological mechanism and therapeutic interventions directed toward preventing and treating perioperative myocardial I–R injury is reviewed.

Pathophysiology of ischemia-reperfusion injury

Intracellular high-energy phosphate depletion

Prolonged ischemia results in a variety of cellular metabolic and ultrastructural changes initiated by a depletion in high-energy phosphates [7]. The absence of normal oxidative phosphorylation within the mitochondria leads to diminished myocardial tissue concentrations of adenosine 5'-triphosphate (ATP) and creatine phosphate. Depletion of adenine nucleotides may persist for hours to days after severe ischemia, partially due to the myocardium's limited capacity for de novo purine synthesis. Initially, when ATP use exceeds the capacity of the myocytes to resynthesize high-energy phosphates, degradation of adenine nucleotides results in the conversion of adenosine diphosphate (ADP) to adenosine monophosphate (AMP). Further sustained reductions in ATP availability result in irreversible myocyte injury associated with sarcolemmal damage, acidosis, and cellular swelling, because ATP-dependent ionic pump function becomes compromised favoring extracellular leakage of potassium (K^+) ions and intracellular entry of Ca^{2+} , sodium (Na^+), and water [8].

Myocardial ischemia is also associated with an accumulation of intracellular lactic acid [9]; a decline in fatty-acid oxidation, which normally provides 60% to 90% of myocardial energy requirements [10]; and a depletion of glutathione, an endogenous intracellular antioxidant [7]. Finally, the characteristic changes in myocardial protein production and degradation may be acute or delayed, which suggests that altered genetic expression of protein synthesis may play a role in I–R injury [11].

Reactive oxygen species

Reperfusion of ischemic tissues results in the formation of toxic ROS, including superoxide anions (O_2^-), hydroxyl radicals (OH^-), hypochlorous acid (HOCl), hydrogen peroxide (H_2O_2), and nitric oxide (NO)- derived peroxynitrite [12]. Normally, hypoxanthine produced from AMP metabolism is further metab-

olized by xanthine dehydrogenase (XD) to xanthine [13]. During ischemia however, XD is converted to xanthine oxidase (XO) by Ca^{2+} -dependent proteases. Unlike XD, which uses nicotinamide adenine dinucleotide (NAD) as an electron acceptor during oxidation of xanthine, XO uses O_2 . During O_2 deprivation, XO is unable to catalyze the conversion of hypoxanthine to xanthine, resulting in the accumulation of excess hypoxanthine. Subsequently, the reintroduction of O_2 during reperfusion permits the formation of ROS from the XO-mediated conversion of excess hypoxanthine and residual xanthine. Although the human myocardium may not have significant quantities of XO, ischemia-induced ROS can be generated by way of the NADPH oxidase system located in polymorphonuclear leukocyte (PMN) cell membranes, dissociation of mitochondrial electron transport, catecholamine auto-oxidization, and free metal ions [7].

The ROS are potent oxidizing and reducing agents that can directly damage cellular membranes, mitochondria, and the sarcoplasmic reticulum, resulting in depressed contractile function [14]. Histologic examination demonstrating evidence of myocardial contraction-band necrosis is the hallmark of ROS involvement in the “oxygen paradox” associated with I–R injury [5]. ROS also indirectly induce leukocyte activation and chemotaxis, by way of Ca^{2+} -mediated activation of plasma membrane phospholipase A2, which form arachidonic acid, an important precursor for eicosanoid synthesis [14,15]. Furthermore, ROS can directly activate complement components and may be responsible in part for the microvascular inflammation that is associated with an imbalance between endothelial cell production of NO and H_2O_2 . Finally, ROS stimulate endothelial cell adhesion molecules and cytokine gene expression by way of activation of nuclear transcription factors, such as nuclear factor (NF)- κ B; in turn, these transcription factors are activated by oxidant stress [5,13–15]. Thus, ROS play a significant direct role in early cellular damage during I–R injury and indirectly stimulate the proinflammatory mediators responsible for further sustained myocardial dysfunction.

Alterations in calcium homeostasis

A “calcium paradox” has also been proposed as a potential mechanism for myocardial I–R injury [5,16]. While the membrane ATP-dependent ionic pump is initially impaired during myocardial ischemia, cytosolic Ca^{2+} and Na^+ concentrations increase. When O_2 delivery is restored, subsequent mitochondrial oxidative phosphorylation reactivates the sarcoplasmic reticulum (SR) Ca^{2+} pump (Ca^{2+} -ATPase) and the sarcolemmal Na^+ pump (Na^+ - K^+ -ATPase). The coordination of these two major cation pumps with the sarcolemmal Na^+ / Ca^{2+} exchanger normally helps to restore ionic gradients. In the presence of intracellular Ca^{2+} overload however, excessive Ca^{2+} sequestration in the SR can cause spontaneous oscillations and cardiac muscle hypercontracture, especially when energy is concurrently restored to the myofibrillar elements. Ultimately, substantial cytoskeletal structural injury causes an irreversible state of hypercontracture-induced sarcomere shortening. The contractile elements eventually become insensitive to calcium (ie, “calcium paradox”), which results in an overall

decrease in myocardial contractility [5,17]. During reperfusion, sarcolemmal stability may also be compromised by excessive water influx and cellular swelling associated with a persistent cytosolic Na^+ overload in the presence of a rapidly normalizing extracellular osmotic load [16,18].

Although intracellular Ca^{2+} overload and ROS can independently contribute to myocardial I–R injury, the pathophysiologic mechanisms are not mutually exclusive. Intracellular Ca^{2+} overload is exacerbated during reperfusion by ROS, which interfere with Ca^{2+} flux at the level of the cell membrane or SR, directly compromise mitochondrial oxidative phosphorylation, and they irreversibly inhibit anaerobic glycolysis [10]. Alternatively, Ca^{2+} -dependent mechanisms promote ROS production by way of protease-mediated XO activation and by damage to the mitochondrial electron transport chain, which facilitates ROS leakage [10]. Thus, ROS and intracellular Ca^{2+} overload are important preliminary mediators of myocardial I–R injury.

Role of endothelial cell–leukocyte interactions

The endothelium plays an essential role in maintaining vascular homeostasis and is particularly vulnerable to the deleterious effects of ischemia and reperfusion injury [13]. Sustained hypoxia interferes with normal transcellular ion and water fluxes, thereby inducing ionic-potential imbalances, cellular edema, and eventual damage to the endothelial cytoskeletal integrity. After prolonged ischemia, the depletion of endothelial energy stores initiates microvascular injury. In addition, endothelial production of certain bioactive agents (eg, endothelin, thromboxane A2 [TxA2]) and proinflammatory gene products (eg, leukocyte adhesion molecules, cytokines) is enhanced, while endothelial cell production of other “protective” gene products (eg, constitutive NO, thrombomodulin) and bioactive agents (eg, prostacyclin, NO) is suppressed [13]. Thus, endothelial ischemia induces a proinflammatory state.

Normal endothelial cell function is further compromised after reperfusion because of the exacerbation of the pathophysiologic processes that began during the initial ischemic insult (Fig 1). ROS play a major role in the pathophysiology

Fig. 1. Endothelial cell-leukocyte interactions during ischemia-reperfusion (I–R) injury. Endothelial cell exposure to ischemia and the restoration of oxygen delivery (O_2), results in the intracellular production of reactive oxygen species (ROS: O_2 ; H_2O_2). Subsequent endothelial cell activation involves multiple signal pathways resulting in decreased production of nitric oxide (NO), increased intracellular calcium (Ca^{++}) concentrations, and increased production of mediators, including platelet activating factor (PAF) and leukotrienes (LTB_4). In addition, the surface expression of selectins (P-selectin, E-selectin) and intercellular adhesion molecules (ICAM, VCAM) is accelerated. Following activation by cytokines and activated complement components (C5a), leukocytes accumulate at the endothelial cell surface and begin loosely adhering or “rolling” by way of the interaction of the selectins (P-selectin, L-selectin). Firm adherence involves interactions between leukocyte β_2 -integrins (CD11a/CD18; CD11b/CD18) and intercellular adhesion molecules. Leukocyte transmigration within endothelial cell junctions is mediated by platelet-endothelial cell adhesion molecule (PECAM), and results in the release of destructive ROS, proteases, and arachidonic acid metabolites (AAM).

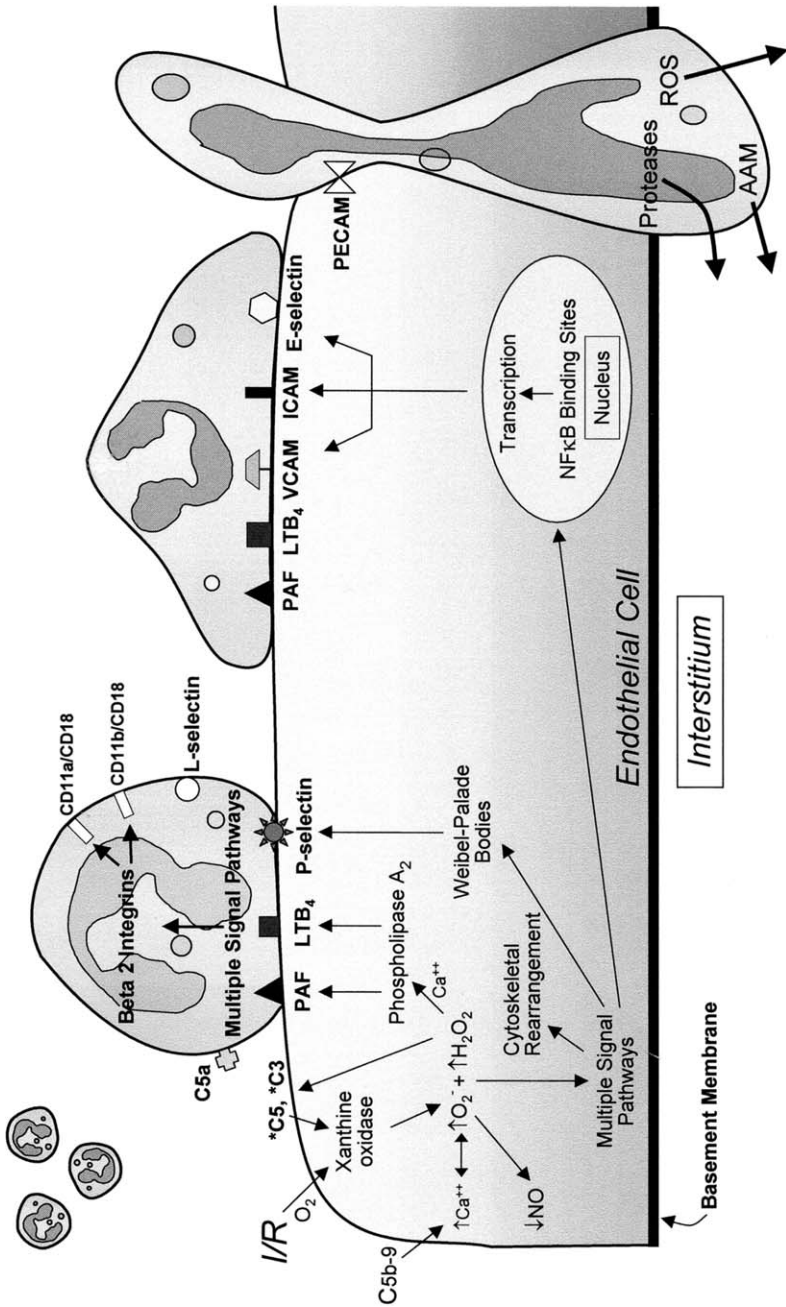

of endothelial I–R injury. Restoration of O₂ flow during reperfusion results in an accumulation of endothelial XO and in the subsequent production of excessive O₂⁻ and H₂O₂, as well as the ROS generated by locally activated leukocytes. In addition, Ca²⁺-dependent endothelial NO-synthase activity decreases after I–R injury, leaving little NO to scavenge the accumulating O₂⁻ [13]. Diminished endothelial NO is responsible for impaired NO-mediated arteriolar smooth muscle relaxation, enhanced platelet aggregation, leukocyte endothelial cell adhesion, and promotion of the capillary filtration response to I–R injury. ROS also promote leukocyte-endothelial cell interactions by mediating the expression of endothelial adhesion molecules, promoting the activation and deposition of complement on endothelial cell membranes, and enhancing phospholipase A2-mediated production of leukotrienes (LTB₄) and platelet activating factor (PAF) [13].

Circulating leukocytes that have been activated systemically (eg, multisystem organ dysfunction, circulatory shock, aortic occlusion-reperfusion, and CPB), or remotely in combination with proinflammatory mediators (eg, tumor necrosis factor α , interleukin-1[IL-1], thromboxane B2 [TxB2], activated complement fragments, and PAF) may play a role in augmenting myocardial I–R injury [19]. Local neutrophil accumulation at the site of myocardial I–R injury however, represents one of the most important components of the overall pathologic process. The neutrophils and the vascular endothelium are involved in establishing a localized chemotactic factor concentration gradient involving complement fragment C5a, IL-8, transforming growth factor (TGF- α), and tumor necrosis factor (TNF) [5].

The neutrophil–endothelial cell interaction involves a sequential progression of steps (Fig 1). The first phase, which involves initial “rolling” and loose adherence of neutrophils to the endothelial surface, is promoted by selectin adhesion molecules, including L-selectin (LECAM-1), P-selectin (GMP-140), and E-selectin (ELAM-1) [5]. L-selectin is constitutively expressed on the surface of neutrophils and monocytes. P-selectin is constitutively synthesized and stored in Weibel-Palade bodies and can be rapidly mobilized to the cellular surface of platelets and endothelial cells in response to inflammatory mediators, such as ROS. L-selectin and P-selectin interact with corresponding cellular surface counter-receptors or ligands composed of the carbohydrate moieties sialyl Lewis X (sLe^x) and A (sLe^A). L-selectin and P-selectin adhesion molecules have an early role in establishing intermittent leukocyte-binding or “rolling,” which tethers neutrophils to the endothelial cell surface, and it leads to PAF-mediated activation [20]. Monoclonal antibodies (MAbs) directed against either P-selectin, L-selectin, or a sLe^x-containing oligosaccharide have been shown to prevent neutrophils from adhering to the coronary endothelium, preserve coronary endothelial function, and attenuate myocardial necrosis after myocardial ischemia and reperfusion [21]. E-selectin is synthesized transiently and is transported to the endothelial cell surface after oxidant-dependent activation of nuclear transcription factors. Compared with the early involvement of L-selectin and P-selectin, E-selectin does not appear to play a sig-

nificant role in myocardial I–R injury, at least within the first 5 hours of reperfusion [5,22].

The transition from neutrophil “rolling” on the endothelial surface to sustained adhesion involves the mobilization and up-regulation of neutrophil CD11/CD18 β_2 integrins, mediated by PAF in conjunction with P-selectin (Fig 1) [23]. During reperfusion, β_2 integrins bind acutely to endothelium-associated complement opsonizing particle, iC3b, to establish firm adhesion. However, further interactions between β_2 integrins and endothelial-derived intercellular adhesion molecules (ICAMs) also mediate firm adhesion and permit further neutrophil recruitment in later phases. In an experimental model of myocardial I–R injury, anti-CD11b MAbs have been shown to reduce leukocyte adhesion and limit MI size [24].

The final phase of neutrophil–endothelial cell interactions involves diapedesis, or trans-endothelial migration of neutrophils through gap junctions between adjacent cells (Fig. 1). Neutrophil transmigration into the interstitial compartment is facilitated by platelet–endothelial cell adhesion molecule-1 (PECAM-1), which is constitutively expressed along endothelial cell junctions [25]. On reaching the extravascular compartment, activated leukocytes release toxic ROS and proteases (eg, collagenase and elastase), resulting in increased microvascular permeability, edema, thrombosis, and parenchymal cell death. Thus, neutrophil–endothelial interactions play a significant role in myocardial I–R injury and involve a complex progression of steps that require several proinflammatory mediators.

Role of the complement system

The complement system is a major component of the humoral immune system and plays a critical role in some of the inflammatory events occurring in myocardial I–R injury [26–28] (see article: “The System Inflammatory Response in Cardiopulmonary Bypass”). This innate cytotoxic defense system is composed of a catalytic cascade of approximately 20 intravascular proteins. A variety of immunologic processes are used to eliminate foreign cells, initiate inflammation, destroy pathogens, and disrupt cell membranes (Fig 2). The complement system is subdivided into three pathways: the classical, the alternative, and the lectin complement pathways. Activation of these pathways occurs sequentially through the proteolytic cleavage and association of precursor molecules. The classic complement pathway activation occurs when antibody/antigen complexes interact with the first complement component (C1) and ultimately cause the formation of the C3 convertase, C4b2a. The alternative complement pathway is antibody-independent and is activated by several mechanisms, including yeast cell walls (zymosan), biomaterials (eg, CPB circuits and hemodialysis tubing), and tissue type plasminogen activator [26–28]. Activation of this pathway leads to the formation of the C3 convertase, C3bBb. The recently described lectin complement pathway (LCP), also an antibody-independent pathway, is activated by binding mannose-binding lectin (MBL) to carbohydrate structures present on the surface

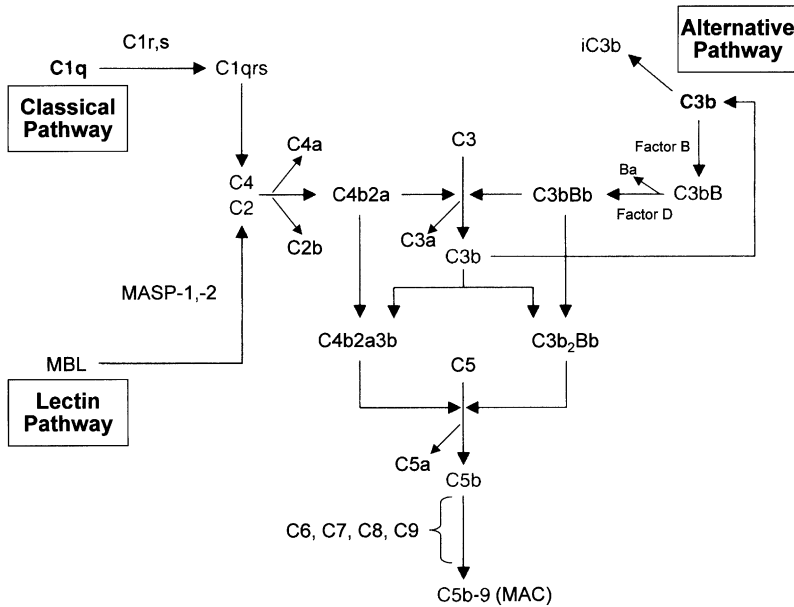

Fig. 2. The three pathways of complement cascade. The antibody-independent classical complement pathway, the antibody-dependent alternative pathway, and the lectin pathway all converge at C3 and lead to the production of terminal complement complex (C5b-9).

of bacteria, yeast, parasitic protozoa, and viruses [29]. Unlike the classic complement pathway, LCP activation does not require antibody, C1, or C1q deposition; instead, it relies on MASP-1 and MASP-2 to cleave C2 and C4 and form the classical C3 convertase.

All three complement pathways merge at C3, which is cleaved by the respective C3 convertase into the anaphylatoxic peptide C3a and the opsonic fragment C3b. C3a is a mast cell and eosinophil chemoattractant and activator [28,30]. Target cell attachment of C3b induces the formation of C5 convertase (C3b₂Bb or C4b2a3b), which subsequently cleaves C5 into C5a and C5b. C5a promotes chemotaxis and activation of leukocytes and the generation of inflammatory mediators. C5b initiates the formation of C5b-9, the membrane attack complex (MAC), and induces targeted endothelial-cell production of chemokines (eg, IL-8, monocyte chemoattractant protein-1) and expression of proinflammatory selectins and adhesion molecules [31]. Multiple target cell “hits” by the pore-forming C5b-9 promote water, electrolyte, and small molecule transcellular fluxes, ultimately resulting in cell lysis and irreversible tissue injury [28,30].

Evidence for the role of activated complement components in myocardial I–R injury includes the indirect effects of anaphylatoxins and the direct effects of C5b-9 in modifying leukocyte responses, altering vascular homeostasis, and

ultimately inducing tissue damage. Although reperfusion may further exacerbate the extent of complement-mediated myocardial injury, complement activation may actually be initiated during ischemia [28]. During ischemia, disruption of myocyte membrane integrity may allow intracellular entry and activation of complement components [30]. Exposed basement membranes, subcellular organelles, mitochondrial particles, cardiolipin, certain sensitizing antibodies, or the fibrinolytic system can each directly activate the classic complement pathway [32]. Activated complement components also play a role in modifying ROS production and Ca^{2+} flux that can contribute to myocardial I–R injury. For example, ROS generation can be directly promoted by way of C5a-induced conversion of XD to XO through endothelial interactions [33]. Ca^{2+} influx is also facilitated by complement activation by way of formation and membrane insertion of C5b-9 [34]. Thus, complement activation plays an important early role in modifying myocardial I–R injury.

Activated complement components are also particularly important facilitators of endothelial cell–leukocyte interactions and vascular injury. The anaphylatoxins C3a, C5a, and C4a act directly on smooth muscle to promote vasodilatation [28,30]. In addition, anaphylatoxin-induced increases in vascular permeability are promoted by way of histamine release from mast cells and basophils, thereby facilitating neutrophil transmigration. C5a can independently promote neutrophil chemotaxis and aggregation and the production of ROS, arachidonic acid metabolites, and proteolytic enzymes. Also, C5a can modify neutrophil adherence to the endothelium by eliciting the release of PAF, which can subsequently activate neutrophils, up-regulate β_2 -integrins, and induce L-selectin shedding [30]. Furthermore, C5a may amplify this inflammatory response by inducing cytokine production [30]. Formation of iC3b, resulting from C3b cleavage, has been demonstrated *in vitro*, with induction of IL-1 stimulated expression of ICAM-1 on endothelial cells [26]. Furthermore, iC3b functions as a specific ligand for the sustained adhesion of leukocytes to the vascular endothelium, by way of binding with β_2 -integrins [5]. This facilitates the oxidative burst and release of proteolytic enzymes during neutrophil phagocytosis [28]. C5b-9 modifies neutrophil–endothelial cell interactions by stimulating production of endothelial von Willebrand factor and rapid translocation of P-selectin from Weibel-Palade bodies to the endothelial surface [30]. C5b-9 also activates endothelial NF- κ B, which increase transcription and expression of leukocyte adhesion molecules [35]. C5b-9 may also alter vascular tone by inhibiting endothelium-dependent relaxation and decreasing endothelial cyclic guanosine monophosphate [28]. Finally, C5b-9 promotes leukocyte activation and chemotaxis and triggers neutrophils to release ROS, proteolytic enzymes, and arachidonic acid metabolites (eg, LTB_4 , prostaglandin E₂, Tx) [30].

Complement activation associated with myocardial I–R injury may also result from antibody-independent activation of the classical complement pathway at C2 and C4 levels by way of the LCP after MBL binds to cell-surface carbohydrates [29]. Although MBL does not normally recognize the body's own tissues, oxidative stress may alter glycosylation of the cell surface membrane, which

leads to an increase in MBL deposition [26]. Thus, complement activation through any of the three delineated pathways may significantly contribute to the pathogenesis of myocardial I–R injury.

Perioperative systemic inflammatory response syndrome

During cardiac surgery requiring CPB, an imbalance in the systemic production of proinflammatory and anti-inflammatory mediators can contribute to organ dysfunction, which originates locally at the site of I–R injury [36]. The pathophysiology of this systemic inflammatory response syndrome (SIRS) involves several interdependent pathways, including the contact system, coagulation-fibrinolytic cascades, complement cascades, and cytokine production.

Several mechanisms have been proposed to account for the etiology of SIRS during cardiac surgery. Nonspecific activators include surgical trauma, blood loss or transfusion, and hypothermia. The inflammatory response can also be indirectly activated by increased systemic concentrations of endotoxin, associated with gut translocation after a mucosal barrier injury caused by splanchnic hypoperfusion [37]. In addition, heparin–protamine complexes can systemically activate inflammatory mediators (eg, complement, histamine, Tx, NO, and antibodies) [36]. Furthermore, inflammatory mediators generated at the site of I–R injury may also contribute to those that are circulating systemically.

During cardiac surgery, SIRS is profoundly affected by the exposure of circulating blood to the bioincompatible surfaces of the CPB extracorporeal circuit. This results in the generation of factor XII and activation of the intrinsic pathway of the coagulation cascade by way of the contact system [6]. The subsequent production of kallikrein activates the kinin–bradykinin system, stimulates C5a production, and leads to the generation of plasmin. Plasmin in turn activates the fibrinolytic system, generates additional contact activation proteins, and promotes C3 cleavage by way of the alternate complement pathway. The extrinsic pathway of the coagulation system is also activated in the perioperative period by the production of tissue factor from endothelium and muscle in response to surgical trauma, inflammatory stimuli, and oxidative or shear stress [36]. Thrombin produced from intrinsic and extrinsic coagulation pathways catalyzes the formation of insoluble fibrin from fibrinogen, which binds the platelet plug to initiate hemostasis.

In cardiac surgical patients, the normal balance of hemostasis is often disturbed. In the presence of significant vascular injury, the concomitant procoagulant activities of thrombin combined with the stimulation for fibrinolysis may become uncontrolled. Additionally, several coagulation proteins, including thrombin and Factor Xa, have proinflammatory properties [38]. Subsequent disseminated intravascular coagulation and microvascular occlusion may contribute to multiorgan dysfunction syndrome. Thus, the combination of endothelial cell, platelet and leukocyte activation, along with circulating cytokines and the procoagulants associated with SIRS, favors a systemic procoagulant/proinflammatory state that can exacerbate local I–R injury.

Treatment of perioperative myocardial ischemia–reperfusion injury

Myocardial I–R injury has been associated with transient reperfusion arrhythmias, myocardial stunning, and irreversible myocardial injury, all of which can contribute to perioperative morbidity and mortality [7]. Ideally, the morbidity associated with perioperative myocardial I–R injury may be diminished by limiting the duration and severity of the initial ischemic insult and by assuring timely reperfusion. However, the aortic cross clamping and CPB still required for the majority of cardiac surgical procedures subjects patients to varying degrees of multiorgan I–R injury. Furthermore, although extracorporeal circuit modification [39] and CABG without CPB (off-pump CABG, [OPCAB]) [40] may reduce inflammatory mediator generation, neither procedure guarantees that myocardial I–R and the associated perioperative morbidity will be entirely prevented.

Several modifications in cardiac surgical technique have been proposed in an attempt to either reduce the duration and severity of myocardial ischemia or reduce the generation of the systemic inflammatory mediators involved in I–R injury (Box 1). These techniques have included use of various cardioplegia recipes and delivery techniques, temperature regulation, CPB circuit modification, bilateral extracorporeal circulation, hemofiltration, leukocyte depletion, minimally invasive surgical techniques, and OPCAB [36]. Modifications of anesthetic techniques, including the use of thoracic epidural anesthesia and analgesia, have also been shown to attenuate the perioperative stress response and myocardial injury after CABG [41]. In addition, several anesthetic agents commonly used during cardiac surgery (eg, sodium thiopental, propofol, opioids, midazolam, and volatile agents) have systemic anti-inflammatory effects [36]. Myocardial gene delivery has also been proposed as a potential myocardial protection technique [42].

Most of the remaining therapeutic strategies have focused primarily on preventing or treating reperfusion injury by administering pharmacologic agents targeted at the most significant proinflammatory mediators associated with myocardial I–R injury, including those directed toward reducing exposure to endotoxins. Many of these proposed strategies have been limited to experimental and animal models of myocardial I–R injury. The following section focuses on pharmacologic interventions, having potential to reduce myocardial I–R injury, that have been investigated in clinical trials in cardiac surgical patients.

Myocardial preconditioning: ischemic and pharmacologic intervention

Ischemic preconditioning (IPC) refers to the phenomenon by which I–R injury can be diminished by prior exposure of the myocardium to repeated brief periods of ischemia [43]. Reimer et al [15] demonstrated that IPC of dog hearts slowed the consumption of high-energy phosphates. Further experimental investigation demonstrated additional myocardial benefits of IPC, including improved ventricular function, reduced myocyte apoptosis, and diminished neutrophil accumulation after I–R. Clinical trials using IPC have demonstrated less myocardial ATP depletion, lower troponin T levels, and a protective effect on

Box 1. Therapeutic strategies to attenuate perioperative myocardial ischemia-reperfusion injury**Surgical/procedural**

Cardiopulmonary bypass circuit modification:

Surface coating

Filters

Hemofiltration

Leukocyte depletion

Temperature

Pulsatile perfusion

Oxygenators: membrane versus bubble

Bilateral extracorporeal circulation

Minimally invasive techniques / OPCAB

Ischemic preconditioning

Thoracic epidural anesthesia

Endotoxin reduction

Selective gut decontamination

Anti-endotoxin antibodies

Anti-endotoxin vaccine

Immunonutrition

Intravascular volume optimization

Pharmacological

Monoclonal antibodies:

Cytokines

Complement

Adhesion molecules

Platelet activating factor antagonists

Endothelin receptor antagonists

Aspirin-triggered lipoxin analogs

Leukotriene antagonists

Protease inhibitors

Na⁺-H⁺ exchange inhibitors

NO- related therapy (L-arginine)

Antioxidants

Corticosteroids

Calcium channel antagonists

Pentoxifylline

Pharmacological preconditioning

Myocardial gene therapy

Direct transfection/transduction of genes or vectors

Transducing cells

Abbreviations: OPCAB, "off-pump" coronary artery bypass graft surgery; NO, nitric oxide.

right ventricular contractility in patients undergoing CABG [44,45]. Factors such as the lack of consistency in the duration and number of IPC and reperfusion periods, the use of surrogate endpoints, ethical considerations involving the use of IPC in high-risk patients, and controversy over its benefit in “cardioplegia-protected” myocardium [46] however, have limited its widespread acceptance.

The IPC mechanism has been further delineated to reveal mechanisms of “early” and “delayed” myocardial protection, as well as the development of pharmacologic strategies that may provide a more practical means of preconditioning the myocardium (Fig 3). K^+_{ATP} channel activation by way of isoflurane inhalation or morphine-mediated δ -1 opioid receptor activation, in addition to adenosine, bradykinin, acetylcholine, catecholamines, and myriad other agents, may also promote myocardial preconditioning [43].

Acadesine

Adenosine and adenosine-regulating agents are recognized for their potential role in mitigating myocardial ischemia [3,47]. The myocardial protective effect of adenosine is mediated through the K^+_{ATP} channel by way of protein kinase C-dependent process [43,47]. Acadesine is a purine nucleoside analog that selectively increases tissue adenosine concentrations during myocardial ischemia. Data from experimental and animal studies demonstrate the beneficial effects of acadesine on postreperfusion ventricular function and dysrhythmias, platelet adherence, and granulocyte accumulation [3]. The effect of acadesine on perioperative MI, stroke, and death was evaluated in a meta-analysis of 5 randomized trials involving 4043 patients undergoing CABG surgery [3]. Acadesine treatment before and during surgery decreased the incidence of the perioperative MI by 27%, decreased cardiac death on postoperative day 4 by 50%, and decreased the composite outcome (MI, cardiac death, or stroke) by 26%. Although routine use of acadesine remains controversial [48], the potential benefit as a perioperative myocardial protective agent warrants further investigation.

Aprotinin

Serine proteases play a central role in the amplification of the contact activation, coagulation, and complement cascades. Consequently, serine protease inhibition may limit systemic generation of inflammatory mediators and similar processes related to local I–R injury in the perioperative period. Aprotinin is a nonspecific serine protease inhibitor that limits excessive blood loss and transfusion requirements in patients undergoing cardiac surgery [49]. In addition, a variety of anti-inflammatory effects have been attributed to aprotinin, including inhibition of platelet activation, leukocyte activation and adhesion molecule expression, contact activation, pro-inflammatory cytokine production, and complement activation [50]. Thus, the administration of aprotinin would be expected to have beneficial effects on perioperative myocardial I–R injury.

Clinical studies have demonstrated that aprotinin is associated with a reduction in post-CPB inotropic support [51] and cardiac enzyme release [52]. Furthermore, in a randomized trial involving 400 cardiac surgical patients and 4 “anti-inflamma-

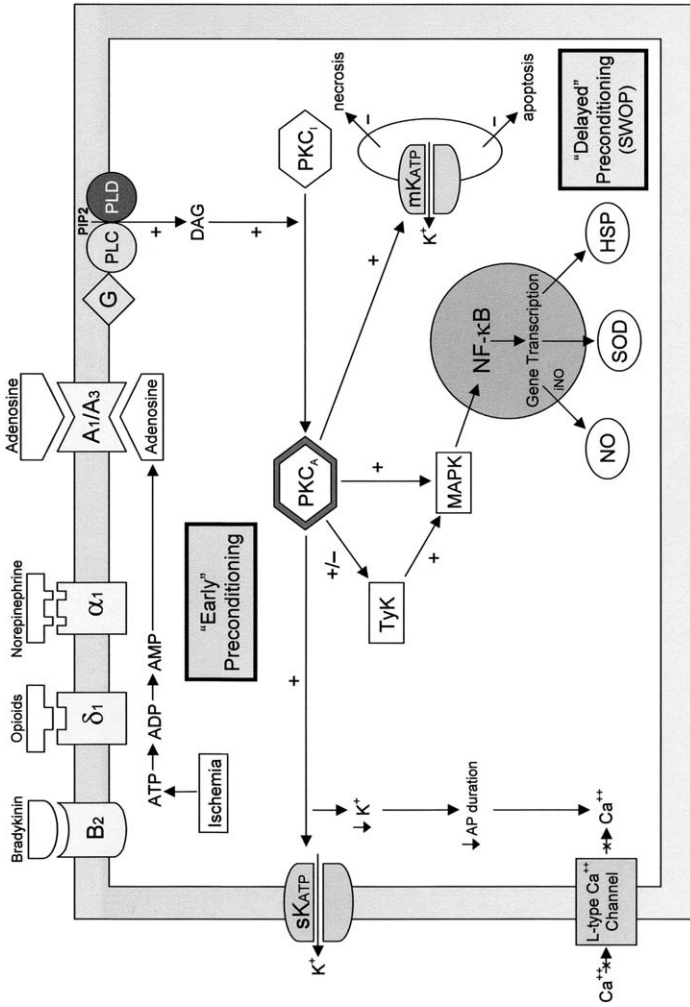

tory” strategies (heparin bonded-circuit, leukocyte depletion, “standard” methylprednisolone, and aprotinin), aprotinin therapy was associated with the greatest reduction in length of hospital stay and cost in the high-risk subgroup [53]. Thus, in the cardiac surgical population, aprotinin does indeed have potential benefits for reducing blood loss and myocardial I–R injury by way of anti-inflammatory serine protease inhibition.

Corticosteroids

Corticosteroids are often considered the gold standard of anti-inflammatory agents. Corticosteroids may protect against myocardial I–R injury by reduced complement activation, diminished proinflammatory (TNF- α , IL-1 β , IL-6, and IL-8) and increased anti-inflammatory (IL-10) cytokine production, attenuated leukocyte activation and adhesion molecule expression, and sequestration [54]. Several clinical studies have suggested that pre-CPB administration of corticosteroids is associated with improved cardiovascular performance and reduced perioperative morbidity [55]. However, the theoretical risk of increased infection and poor wound healing, in addition to the controversy regarding efficacy and dosing regimens, have limited the routine perioperative use of corticosteroids [36].

ROS scavengers and antioxidants

ROS are produced in significant quantities during I–R and play a major role in cellular injury. Protective endogenous myocardial antioxidants, including glutathione reductase, superoxide dismutase, and catalase can become depleted in the presence of overwhelming ROS generation, thereby reducing natural defenses and scavenging capacity. Thus, the use of exogenous free radical scavengers and antioxidants may be useful for ameliorating the deleterious consequences of I–R injury [36,56].

Fig. 3. Signaling mechanisms involved in myocardial preconditioning. Ischemia-induced activation of adenosine A1-receptors, eventual K^+ ATP channels activation and a decrease in intracellular calcium (Ca^{2+}), is responsible for the “early preconditioning” (1–2 hours) phase of cardioprotection. Induction of new protein synthesis including heat shock proteins (HSP), nitric oxide (NO), and antioxidants (SOD: super oxide dismutase) by way of the promotion of gene transcription is responsible for a “delayed, second window of myocardial protection” (SWOP), which reappears 12 to 24 hours after reperfusion. Receptor activation by several different agents (bradykinin, opioids, catecholamines, isoflurane) may permit pharmacological preconditioning through similar intracellular signaling mechanisms. ATP: adenosine triphosphate; ADP: adenosine diphosphate; AMP: adenosine monophosphate; B_2 : bradykinin receptor type 2; δ : opioid delta receptor; α : alpha adrenergic receptor type 1; A_1/A_3 : adenosine receptor types 1 and 3; G: G regulatory protein; PLC/PLD: phospholipase C and D; PIP₂: phosphoinositol biphosphate; DAG: diacylglycerol; PKC₁ and PKC_A: protein kinase C inactive and active forms; sKATP: sarcolemmal, ATP-dependent, potassium channel; mKATP: mitochondrial, ATP-dependent, potassium channel; TyK: tyrosine kinase; MAPK: mitogen activated protein kinase; NF- κ B: nuclear factor kappa B; iNO: inducible nitric oxide synthase. (From Chen V, Body S, Sherman S. Myocardial preconditioning: characteristics, mechanisms, and clinical applications. *Sem Cardiothorac Vasc Anesth* 1999;3:85–97; with permission.)

Although several antioxidants have been investigated in experimental models of myocardial O₂ deprivation and have been shown to successfully salvage myocardium or to attenuate the sequelae of myocardial ischemia, there is a relative paucity of clinical data demonstrating their benefits [57]. Several commonly encountered agents, however, may have some beneficial antioxidant properties. Natural antioxidants such as vitamin C (ascorbic acid) and E (α -tocopherol) have been shown to effectively scavenge ROS and improve cardiovascular function after CABG surgery [56]. Allopurinol, a potent XO inhibitor, has also been associated with myocardial protection in cardiac surgical patients, although its efficacy remains controversial [36,58]. In addition, mannitol, by virtue of its many hydroxyl groups [56], has been shown to attenuate ROS generation during cardiac surgery requiring CPB [36]. Finally, some commonly used cardiovascular agents, including the β -blocker propranolol, calcium channel antagonists, and angiotensin-converting enzyme inhibitor, also have cytoprotective antioxidant properties [7,56]. Nevertheless, clinical studies attempting to preserve perioperative myocardial function by diminishing reduced-oxygen intermediates have generally yielded equivocal results.

Complement inhibition

Delineation of the complement cascade components, endogenous regulatory mechanisms, and interactions between different pathways has provided the foundation for developing novel pharmacologic strategies aimed at reducing myocardial I–R injury and its associated morbidity [27]. Although a variety of complement inhibitors have been developed, most investigations have been limited to animal and experimental models of extracorporeal circulation and I–R injury. However, a few of these agents have been investigated in the clinical environment. Nafamostat, a broad spectrum synthetic serine protease inhibitor of C1s, Factor D, and the C3/C5 convertases has been shown to decrease serum complement hemolytic activity and IL-6 and IL-8 production in patients undergoing CPB [59]. C1 esterase inhibitor (C1-INH) was administered as “rescue therapy” in three patients who became hemodynamically unstable after failed percutaneous angioplasty, and consequently required emergent surgical revascularization [60]. Hemodynamic stability was achieved in all 3 patients within 24 hours of drug administration, suggesting that myocardial I–R may be attenuated by inhibition of the classic or LCP.

To date, two complement inhibitors (soluble CR1 [sCR1] and a monoclonal anti-C₅ antibody [Pexelizumab]) have been administered to cardiac patients in large-scale clinical trials. Soluble CR1, an inhibitor of the C3/C5 convertases and cofactor of C3b and C4b inactivation, attenuates myocardial I–R injury in animals and reduces systemic inflammation in cardiac surgical patients undergoing CPB [27]. A recently terminated randomized, double-blinded, placebo-controlled trial involving the administration of a recombinant form of sCR1 (TP10: AVANT Immunotherapeutics, Inc.; Needham, MA) to 564 high-risk cardiac surgical patients, however, failed to demonstrate any benefit on the primary endpoint of death, MI, prolonged ventilation, or prolonged requirement

for intraaortic balloon counterpulsation (AVANT Immunotherapeutics, Inc.; Needham, MA, Press Release, 2/20/02). A humanized, single chain, monoclonal anti-C5 antibody (Pexelizumab: Alexion Pharmaceuticals, Inc. Cheshire, CT) was also investigated in a Phase I, randomized, placebo-controlled trial involving 35 patients undergoing CABG surgery and who required CPB. Patients receiving the highest dose of pexelizumab (20 mg/kg bolus) demonstrated significantly attenuated complement activation, leukocyte activation, myocardial injury, blood loss, and cognitive dysfunction [61]. In a subsequent Phase II multicenter trial involving 914 patients undergoing CABG with or without valve surgery, a benefit in the primary composite endpoint (death; new Q-wave or non-Q-wave [CK-MB >60 ng/mL] MI; left ventricular dysfunction; and new central neurologic deficit) was not demonstrated between patients who received placebo versus those who received pexelizumab [62]. Post-hoc analysis revealed however, a significant reduction in the composite number of deaths or MIs (CK-MB \geq 100 ng/mL) in the isolated CABG subgroup receiving bolus plus infusion of the study drug (2.0 mg/kg + 0.05 mg/kg infusion over 24 hours). The results of this trial have been used to establish the composite clinical endpoints for the cardiovascular and neurologic dysfunction in a larger scale Phase III trial, that is currently investigating the role of complement activation in CPB-induced systemic inflammation and I–R injury.

Na⁺/H⁺ exchange (NHE) inhibitors

The NHE is a sarcolemmal protein that facilitates the exchange of intracellular H⁺ for extracellular Na⁺ [35]. Myocardial ischemia results in an increase in intracellular H⁺ that is exchanged for Na⁺ by activation of the dominant myocardial NHE isoform (NHE-1). The subsequent increase in intracellular Na⁺ promotes Na⁺-Ca²⁺ exchange, resulting in an accumulation of intracellular Ca²⁺ as the ATP-dependent Na⁺-K⁺ pump becomes dysfunctional. Excessive intracellular Ca²⁺ then facilitates myocyte injury. During sustained ischemia, NHE activity is usually self-limited because of the transmembrane ionic equilibrium that is eventually achieved, but reperfusion reestablishes an H⁺ concentration gradient from the intracellular to extracellular space, thereby promoting intracellular Ca²⁺ overload, which results in myocyte hypercontraction and cardiac dysfunction. Thus, NHE inhibitors such as cariporide and eniporide may attenuate myocardial I–R injury by preventing excessive intracellular Na⁺ and Ca²⁺ overload.

In a clinical trial involving more than 11,000 patients who received cariporide and who were at high risk for myocardial ischemia (ie, unstable angina, high-risk percutaneous angioplasty, high-risk CABG), no benefit was demonstrated for the primary endpoint (death or MI) or overall risk reduction [63]. However, CABG patients receiving the highest dose (120 mg every 8 hours for 2–7 days) experienced a 25% risk reduction and a 7% reduction in the incidence of non-Q-wave MI. In addition, the rate of Q-wave MI was reduced by 32% across all groups. The efficacy of cariporide in attenuating myocardial I–R injury is being further investigated in a high-risk CABG population.

Summary

Myocardial I–R injury contributes to adverse cardiovascular outcomes after cardiac surgery. The pathogenesis of I–R injury is complex and involves the activation, coordination, and amplification of several systemic and local proinflammatory pathways (Fig. 4). Treatment and prevention of perioperative morbidity associated with myocardial I–R will ultimately require a multifocal approach. Combining preoperative risk stratification (co-morbidity and surgical complexity), minimizing initiating factors predisposing to SIRS, limiting ischemia duration, and administering appropriate immunotherapy directed toward systemic and local proinflammatory mediators of I–R injury, should all be considered. In addition, the role of the genetic-environmental interactions in the pathogenesis of cardiovascular disease is also being examined. Thus, in the near future, preoperative screening for polymorphisms of certain inflammatory and coagulation genes should inevitably help reduce morbidity by permitting the identification of high-risk cardiac surgical patients and introducing the opportunity for gene therapy or pharmacogenetic intervention [42,64].

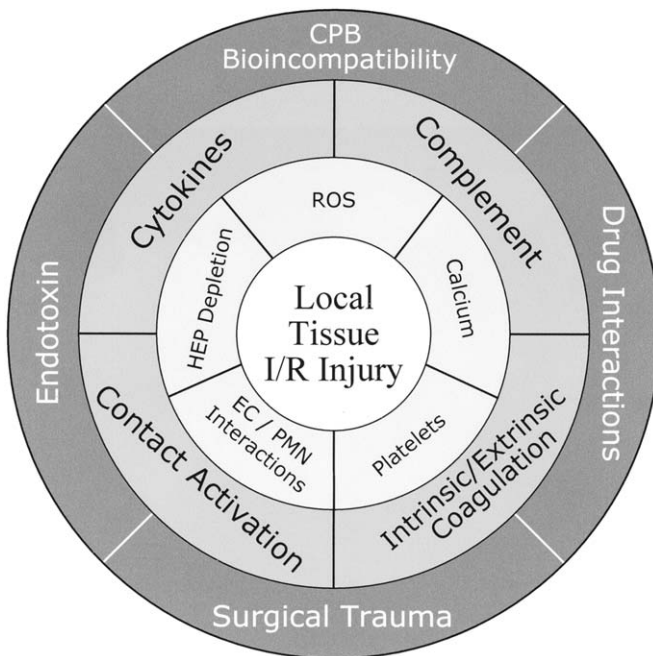

Fig. 4. Interaction of local and systemic proinflammatory pathways involved in the pathogenesis of ischemia reperfusion (I/R) injury. ROS: reactive oxygen species; ED: endothelial cells; PMN: polymorphonuclear cells; HEP: high-energy phosphates; CPB: cardiopulmonary bypass.

References

- [1] Hammermeister K, Burchfiel C, Johnson R, et al. Identification of patients at greatest risk for developing major complications at cardiac surgery. *Circulation* 1990;82:380–9.
- [2] Mangano D. Cardiovascular morbidity and CABG surgery: a perspective: epidemiology, costs, and potential therapeutic solutions. *J Card Surg* 1995;10:366–8.
- [3] Mangano D. Effects of acadesine on myocardial infarction, stroke, and death following surgery: a meta analysis of the 5 international randomized trials. *JAMA* 1997;277:325–32.
- [4] Tu J, Jaglal S, Naylor C. Multicenter validation of a risk index for mortality, intensive care unit stay, and overall hospital length of stay after cardiac surgery. (Steering Committee of the Provincial Adult Cardiac Care Network of Ontario.) *Circulation* 1995;91:677–85.
- [5] Park J, Lucchesi B. Mechanisms of myocardial reperfusion injury. *Ann Thorac Surg* 1999; 68:1905–12.
- [6] Royston D. Systemic inflammatory responses to surgery with CPB. *Perfusion* 1996;11:177–89.
- [7] Maxwell S, Lip G. Reperfusion injury: a review of the pathophysiology, clinical manifestations and therapeutic options. *Internat J of Cardiol* 1997;58:95–117.
- [8] Jennings E, Reimer K, Hill M, et al. Total ischemia in dog hearts in vitro. I. Comparison of high energy phosphate production, utilization and depletion, and of adenine nucleotide catabolism in total ischemia in vitro vs. severe ischemia in vivo. *Circ Res* 1981;49:892–900.
- [9] Ganz P, Abben R, Barry W. Dynamic variations in resistance of coronary arterial narrowings in angina pectoris at rest. *Am J Cardiol* 1987;59:66.
- [10] Camici P, Marraccini P, Lorenzoni R. Metabolic markers of stress-induced myocardial ischemia. *Circulation* 1991;83(Suppl III):III8.
- [11] Mehta H, Popovich B, Dilman W. Ischemia induces changes in the level of mRNAs coding for stress protein 71 and creatine kinase. *M Circ Res* 1988;63:512.
- [12] Ambrosio G, Weisfeldt M, Jacobus W, et al. Evidence for a reversible oxygen radical-mediated component of reperfusion injury: reduction by recombinant human superoxide dismutase administered at the time of reflow. *Circulation* 1987;282:75.
- [13] Carden D, Granger D. Pathophysiology of ischaemia-reperfusion injury. *J Pathol* 2000;190: 255–66.
- [14] Toyokuni S. Reactive oxygen species-induced molecular damage and its application in pathology. *Pathol Int* 1999;49:91–102.
- [15] Collard C, Gelman S. Pathophysiology, clinical manifestations, and prevention of ischemia-reperfusion injury. *Anesthesiology* 2001;94:1133–8.
- [16] Piper H, Garcia-Dorado D. Prime causes of rapid cardiomyocyte death during reperfusion. *Ann Thorac Surg* 1999;68:1913–9.
- [17] Gross G, Kersten J, Warltier D. Mechanisms of post-ischemic contractile dysfunction. *Ann Thorac Surg* 1999;68:1898–904.
- [18] Insete J, Garcia-Dorado D, Ruiz-Meana M, et al. The $\text{Na}^+ - \text{H}^+$ exchange occurring during hypoxia in the genesis of reoxygenation-induced myocardial oedema. *J Mol Cell Cardiol* 1997;29:1167–75.
- [19] Entman M, Michael M, Rossen R, et al. Inflammation in the course of early myocardial ischemia. *FASEB* 1991;5:2529–37.
- [20] Butcher E. Leukocyte-endothelial cell adhesion recognition: Three (or more) steps to specificity and diversity. *Cell* 1991;67:1033–6.
- [21] Buerke M, Weyrich A, Murohara T, et al. Humanized monoclonal antibody DREG-200 directed against L-selectin protects in feline myocardial reperfusion injury. *J Pharm Exp Ther* 1994; 271:134–42.
- [22] Weyrich A, Buerke M, Albertine K, et al. Time course of coronary vascular endothelial adhesion molecule expression during reperfusion of the ischemic feline myocardium. *J Leukoc Biol* 1995; 57:45–55.
- [23] Lefer A. Role of the β_2 -integrins and immunoglobulin superfamily members in myocardial ischemia-reperfusion. *Ann Thorac Surg* 1999;68:1920–3.

- [24] Simpson P, Todd III R, Fantone J, et al. Reduction of experimental myocardial injury by a monoclonal antibody (anti-Mo1), anti-CD11b) that inhibits leukocyte adhesion. *J Clin Invest* 1988;81:624–9.
- [25] Muller W, Weigl S, Deng X, et al. PECAM-1 is required for transendothelial migration of leukocytes. *J Exp Med* 1993;178:449.
- [26] Collard C, Lekowski R, Jordan J, et al. Complement activation following oxidative stress. *Mol Immunol* 1999;36:941–8.
- [27] Sherman S, Collard C. Role of the complement system in ischemic heart disease: potential for pharmacological intervention. *BioDrugs* 2001;15:595–607.
- [28] Stahl G. Reperfusion-injury during surgery: role of the endothelium, oxidative stress and complement activation. *New Surgery* 2001;1:62–6.
- [29] Turner M. The lectin pathway of complement activation. *Res Immunol* 1997;147:110–5.
- [30] Kilgore K, Shen J, Miller B, et al. The complement system in myocardial ischemia reperfusion injury. *Cardiovasc Res* 1994;28:437–44.
- [31] Kilgore K, Schmid E, Shanley T, et al. Sublytic concentrations of the membrane attack complex of complement induce endothelial interleukin-8 and monocyte chemoattractant protein-1 through nuclear factor-kappa B activation. *Am J Pathol* 1997;150:2019–31.
- [32] Rossen R, Micheal L, Kagiyaama A, et al. Mechanism of complement activation following coronary artery occlusion: evidence that myocardial ischemia causes release of constituents of myocardial subcellular origin which complex with the first component of complement. *Circ Res* 1988;62:572–84.
- [33] Amsterdam E, Stahl G, Pan H, et al. Limitation in reperfusion injury by a monoclonal antibody to C5a during myocardial infarction in pigs. *Am J Physiol Heart Circ Physiol* 1995;286:H448–57.
- [34] Kim S, Carney D, Hammer C, et al. Nucleated cell killing by complement: effects of C5b-9 channel size and extracellular Ca²⁺ on the lytic process. *J Immunol* 1987;138:1530–6.
- [35] Karmazyn M. Pharmacology and clinical assessment of cariporide for the treatment of coronary artery diseases. *Exp Opin Invest Drugs* 2000;9:1099–108.
- [36] Laffey J, Boylan J, Cheng D. The systemic inflammatory response to cardiac Surgery. *Anesthesiology* 2002;97:215–52.
- [37] Martinez-Pellus A, Merino P, Bru M, et al. Endogenous endotoxemia of intestinal origin during cardiopulmonary bypass. *Intens Care Med* 1997;23:1251–7.
- [38] Cicala C, Cirono G. Linkage between inflammation and coagulation: an update on the molecular basis if the crosstalk. *Life Sci* 1998;62:1817–24.
- [39] Te Vethius H, Baufreron C, Jansen P, et al. Heparin coating of extracorporeal circuits inhibits contact activation during cardiac operations. *J Thorac Cardiovasc Surg* 1997;114:117–22.
- [40] Ascione R, Lloyd C, Underwood M, et al. Inflammatory response after coronary revascularization with or without cardiopulmonary bypass. *Ann Thorac Surg* 2000;69:1198–204.
- [41] Riedel B, Wright I. Epidural anesthesia in coronary artery bypass grafting surgery. *Curr Opin Cardiol* 1997;12:515–21.
- [42] Das D, Engelman R, Maulik N, et al. Molecular targets of gene therapy. *Ann Thorac Surg* 1999; 68:1929–33.
- [43] Chen V, Body S, Sherman S. Myocardial preconditioning: characteristics, mechanisms, and clinical applications. *Sem Cardiothorac Vasc Anesth* 1999;3:85–97.
- [44] Jenkins D, Pugsley W, Alkhulaifi A, et al. Ischaemic preconditioning reduces troponin T release in patients undergoing coronary artery bypass surgery. *Heart* 1997;77:314–8.
- [45] Wu Z, Tarkka M, Pehkonen E, et al. Beneficial effects of ischemic preconditioning on right ventricular function after coronary artery bypass grafting. *Ann Thorac Surg* 2000;70:1551–7.
- [46] Cleveland J, Meldrum D, Rowland R, et al. Preconditioning and hypothermic cardioplegia protect the human heart equally against ischemia. *Ann Thorac Surg* 1997;63:147–52.
- [47] Ely S, Berne R. Protective effects of adenosine in myocardial ischemia. *Circulation* 1992;85: 893–904.
- [48] Warltier D, Pagel P, Kersten J. Approaches to the prevention of myocardial ischemia. *Anesthesiology* 2000;92:253–9.

- [49] Levy J, Pifarre R, Schaff H, et al. A multicenter, double-blind, placebo-controlled trial of aprotinin for reducing blood loss and the requirement for donor-blood transfusion in patients undergoing repeat coronary bypass grafting. *Circulation* 1995;92:2236–44.
- [50] Mojciak C, Levy J. Aprotinin and the systemic inflammatory response after cardiopulmonary bypass. *Ann Thorac Surg* 2001;71:745–54.
- [51] Wippermann C, Schmid F, Eberle B, et al. Reduced inotropic support after aprotinin therapy during pediatric cardiac operations. *Ann Thorac Surg* 1999;67:173–6.
- [52] Wendel H, Heller W, Michel J, et al. Lower cardiac troponin T levels in patients undergoing cardiopulmonary bypass and receiving high-dose aprotinin therapy indicate reduction of perioperative myocardial damage. *J Thorac Cardiovasc Surg* 1995;109:1164–72.
- [53] Gott J, Cooper W, Schmidt F, et al. Modifying risk for extracorporeal circulation: trial of four anti-inflammatory strategies. *Ann Thorac Surg* 1998;66:747–53.
- [54] Jansen N, van Oeveren W, van Vliet M, et al. The role of different types of corticosteroids on the inflammatory mediators of cardiopulmonary bypass. *Eur J Cardiothorac Surg* 1991;5:211–7.
- [55] El Azab S, Rosseel P, de Lange J, et al. Dexamethasone decreases the pro- to anti-inflammatory cytokine ratio during cardiac surgery. *Br J Anaesth* 2002;88:496–501.
- [56] Kukreja R, Hess M. Free radical scavengers. In: Grace P, Mathie R, editors. *Ischaemia-Reperfusion Injury*. London: Blackwell Science; 1999. p. 293–311.
- [57] Bolli R. Oxygen-derived free radicals and myocardial reperfusion injury: an overview. *Cardiovasc Drugs Ther* 1991;5(Suppl):249–68.
- [58] Castelli P, Condemi A, Brambillasca C, et al. Improvement of cardiac function by allopurinol in patients undergoing cardiac surgery. *J Cardiovasc Pharmacol* 1995;25:119–25.
- [59] Sawa Y, Shimazaki Y, Kadoba K, et al. Attenuation of cardiopulmonary bypass-derived inflammatory reactions reduces myocardial reperfusion injury in cardiac operations. *J Thorac Cardiovasc Surg* 1996;111:29–35.
- [60] Bauernschmitt R, Bohrer H, Hagl S. Rescue therapy with C1- esterase inhibitor concentrate after emergency coronary surgery for failed PTCA. *Intensive Care Med* 1998;24:635–8.
- [61] Fitch J, Rollins S, Matis L, et al. Pharmacology and biological efficacy of a recombinant, humanized, single-chain antibody C5 complement inhibitor in patients undergoing coronary artery bypass graft surgery with cardiopulmonary bypass. *Circulation* 1999;100:2499–506.
- [62] Sherman S, Nussmeier N, Rollins S, et al. Pexelizumab reduces death and myocardial infarction in CABG patients requiring CPB: results of the 914 patient phase II trial. *Circulation* 2001;104:II–47.
- [63] Theroux P, Chaitman B, Danchin N, et al. Inhibition of the sodium-hydrogen exchanger with cariporide to prevent myocardial infarction in high-risk ischemic situations: main results of the GUARDIAN trial. *Circulation* 2000;102:3032–8.
- [64] Andreotti F, Porto I, Crea F, et al. Inflammatory gene polymorphisms and ischaemic heart disease: review of population association studies. *Heart* 2002;87:107–12.